

INSTRUCTION MANUAL

Before handling the machine, this instruction manual should be read through carefully to familiarize yourselves with contents of the manual.

The machine should be handled by skilled operator. Consideration should be given so that this instruction manual will reach to the user of this machine. This manual should be kept in file so as to be serviceable at any time.

Before handling this machine, be sure to read this manual and other appendices carefully to familiarize yourselves with contents of the manual for proper operation. Start on using this machine after having been well acquainted with all the equipment knowledge, safety information, and cautionary instructions. The rank of safety precautions is classified into “WARNING” and “CAUTION” in this instruction manual.





WARNING

Where occurrence of dangerous situation such as death or serious injury is presumable in the case of mishandling.



CAUTION

Where occurrence of dangerous situation such as light injury or only physical damage is presumable in the case of mishandling.

Even such matters which full under  **CAUTION** may possibly lead to serious results depending upon the circumstances. Be sure to observe the instructions given by  **CAUTION** where every description covers important notes.



WARNING

- * Customers should never make modification to the product, which may cause damage to the product or may cause personal injury.
- * Do not use the product in the explosive atmospheres, which may cause explosion, fire or an accident resulting in injury or death.



CAUTION

- * Use the product exactly to the specifications, otherwise, damage or personal injury may occur.



WARNING

- * Such works as transportation, unpacking, grounding, piping, wiring, operation, maintenance / inspection should be performed by skilled persons with sufficient knowledge. Otherwise, electric shock, fire, damage to the product or personal injury may occur.



CAUTION

- * Do not insert your finger or any other foreign object into the opening of the product, which may cause electric shock, fire, damage to the product or personal injury.

Description of coupling parts and type

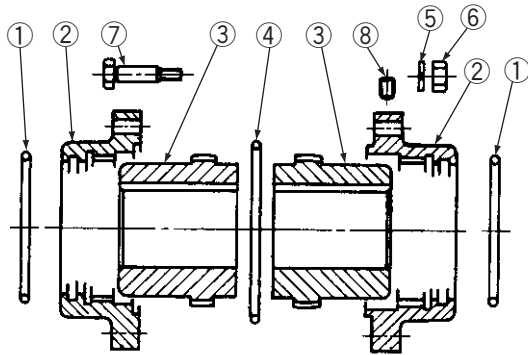

1. O-ring (for sealing the case end)
2. Coupling case
3. Coupling center
4. O-ring (for sealing case jointing surfaces)
5. Washer
6. Nut
7. Reamer bolt (for fastening the case)
8. Plug

The above figure illustrates the parts of Type GC-SSM Coupling. Type GC-CCM has a coupling case of a side cover construction in which the fitting portion of O-ring ① for the case end of a coupling case ② is securely fastened to the coupling case with bolts.

Types GC-SEM and GC-CEM are modifications of Types GC-SSM and GC-CCM, each one side of which is converted into a fixed (rigid) flange. Types SEM and CEM permit only an angular misalignment and do not permit any parallel misalignment in one set.

In case a parallel misalignment is required, use two sets of them as one pair through an intermediate shaft.

Transportation/unpacking

⚠ WARNING

- When the product is suspended from overhead for the purpose of transportation, never stand under the product. There is a danger of an accident resulting in injury or death caused by dropping of the product.

⚠ CAUTION

- Before lifting the machine, check the machine weight and lifting procedure, and use such hauling tools as are possessed of rated capacity of lifting not less than the machine weight. There is a possible danger of failure and injury caused by falling-off and turnover.
- Unpack the machine after making sure of its top and bottom. There is a possible danger of failure and injury caused by turnover.

Method of Fitting

⚠ CAUTION

Disassembly/assembly should be performed by skilled persons with sufficient knowledge (those who well understand the structure and function and can carry out the operation properly). Incomplete operation may cause damage to the product.

1. Cleaning

Before assembling, all parts of the GC coupling should fully be checked and thoroughly be cleaned. This is for the purpose of removing a rustpreventive agent applied on the coupling and preventing foreign matters from mingling therein. Be sure to practice these works also when reassembling the parts after disassembling. Use light oil for cleaning. However, by no means use thinner, because it would cause damage to O-ring.

2. Assembling

When fitting the coupling center (or rigid) to the shaft, heat the coupling center in heated oil or in a soaking pit (up to max. 140°C), or cool the shaft in liquid nitrogen, etc., in order to differentiate the temperatures between the coupling and the shaft.

Then, assemble them with special care not to do damage to them. (By no means heat the tooth surfaces of the coupling center directly with flame.)

When assembling them, take care not to forget to put the case, covers and O-ring in place.

in order to avoid oil leakage from a part of the keyway, apply a viscous sealing agent or use a sealing tape thereto. In case flat head bolts are used inside the coupling, lock them by caulking or spot welding after fitting of those.

3. Alignment

The Types GC-SSM and GC-CCM couplings can absorb some amounts of parallel misalignment, angular misalignment and floating in axial direction. (The Types GC-SEM and GC-CEM couplings, cannot absorb parallel misalignment in one set.) A large misalignment, however, will shorten a life of the coupling extremely, so that perform the alignment work in due consideration of the shaft arising from load operation.

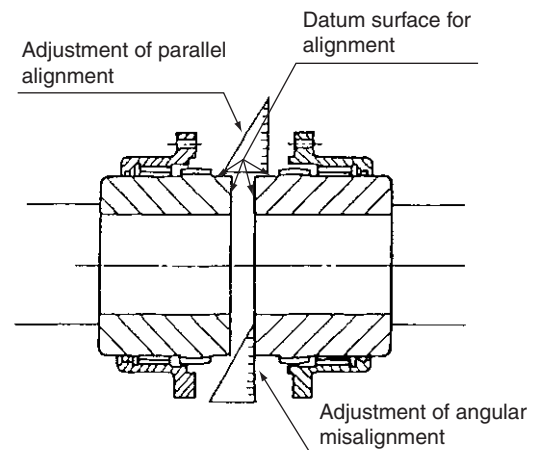

Fig. 1 Datum surfaces for alignment and method of alignment

Align the shaft centers as accurately as possible by using a dial gauge, thickness gauge or wedged gauge without misalignment on the datum surfaces (refer to Fig. 1).

4. Fastening of Flange

⚠ CAUTION

- Do not touch the key groove of shaft end and the acute part of corner of the machine direct by unarmed hand. There is a possible danger of suffering injuries.
- When coupling with the companion machine, keep the centering accuracy within the control value as shown in the instruction manual, drawing, etc. There is a possible danger of failure caused when the machine is used beyond the control value.
- Before coupling with the companion machine, check for the direction of rotation. There is a possible danger of failure and injury caused depending upon the difference in the rotating direction.
- Protect the exposed rotating part with safety cover or the like. There is a possible danger of injury caused by entanglement.

O-ring is inserted between the jointing surfaces of the cases, so that care must be taken to set the ring in correct place, and fasten the cases with reamer bolts evenly. In this case, assemble them applying oil to outer circumferences of the coupling center boss and applying a non-drying non-solvent type liquid packing agent on the jointing surfaces of O-ring becomes free from damages and the assembly work will be simplified.

Fitting marks being punched on both cases of the Types GC-CCM and GC-CEM couplings, check them up in assembling.

5. Oil Supply

Remove two oil plugs, and feed the specified lubricating oil from the upper plug hole until it flows out of the other lower plug hole. (refer to the article on lubricating oil.)

After this, securely tighten oil plugs by applying a sealing agent for use in the keyway or by using a sealing tape.

⚠ CAUTION

- The machine is not filled up with lubricating oil. Before starting on operation, fill the machine with the lubricating oil of the type as recommended by instruction manual, drawing, etc. up to the specified level. The machine will result in failure if it is put in running without lubricating oil or in the state of short of oil.

6. Feeding oil

Remove two oil plugs, and feed the specified lubricating oil from the upper plug hole until it flows out of the other lower plug hole.

(Referring should be made to the article of lubricating oil.) After feeding oil, securely tighten the oil plugs by using the sealing agent for use in the keyway or by using a sealing tape.

Starting Operation

⚠ WARNING

- During operation, never gain access to or come in contact with rotators (shaft etc.). There is a possibility of the accident of human body caused by entanglement.

⚠ CAUTION

- Do not use the machine under the load exceeding the rated value. There is a possibility of failure and injury.
- In case of abnormality, stop the machine forthwith to investigate into the cause of abnormality and never operate the machine until remedial actions have been taken. There is a possibility of failure and injury.

Lubricating Oil

Lubricating oil is indispensable for stable operation of GC coupling. Special care should be paid not to forget to feed oil and to oil leakage. Use lubricating oil equivalent to gear oil; JIS K2219 Kind to ISO VG680 with extreme-pressure additive. Especially in case of high ambient temperature, extremely overload operation, frequent normal and reversing runnings, and a large parallel misalignment and angular misalignment ; be sure to use high viscous gear oil of 70 -110 cst at 98.9°C.

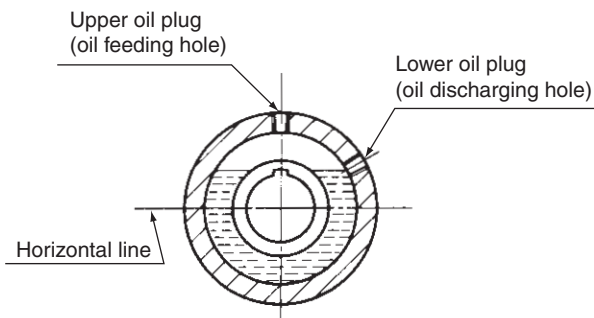

Fig. 2 Method of Oil supply

For feeding lubricating oil, remove two plugs as shown in the above Fig. 2, then feed the recommended oil from the upper plug hole until it flows out of the lower plug hole. In case of cold weather or viscous oil, warm the lubricating oil up to approx. 40°C so as to feed it smoothly.

Table 1 List of lubricating oil brands

Maker	Oil equivalent to JIS KIND 2 ISO VG680	Oil equivalent to 70-110 cst (98.9°C)	Grease equivalent to JIS KIND 4 No.1
IDEMITSU KOSAN CO.,LTD.	DAPHNE SUPER GEAR OIL 680		DAPHNE GREASE MP No.1
EXXON MOBIL CORPORATION	MOBIL GEAR 600XP 680		MOBILUX EP1
Shell Lubricants Japan K.K.	SHELL OMALA S2 G 680		SHELL ALVANIA EP GREASE 1
ENEOS	BONNOC TS680	BONNOC M 3800	EPINOC GREASE AP(N) 1
COSMO OIL LUBRICANTS CO.,LTD.	COSMO GEAR SE 680		COSMO SHUCHU GREASE No.1

Table 2 List of required lubricating oil amounts

Types GC-SSM and GC-SEM

Type Size	SSM		SEM	
	Gear oil (L)	Grease (g)	Gear oil (L)	Grease (g)
100	0.043	38	0.032	29
112	0.055	50	0.042	38
125	0.072	65	0.056	51
140	0.11	100	0.085	77
160	0.14	130	0.11	100
180	0.18	160	0.14	130
200	0.24	220	0.18	170
224	0.36	320	0.29	270
250	0.53	480	0.41	370
280	0.69	620	0.56	510
315	1.1	1000	0.9	810
355	1.3	1200	1.1	1000
400	2.0	1800	1.6	1440

Types GC-CCM and GC-CEM

Type Size	CCM		CEM	
	Gear oil (L)	Grease (kg)	Gear oil (L)	Grease (kg)
450	2.6	2.3	2.1	1.9
500	3.8	3.4	3.1	2.8
560	4.6	4.1	3.8	3.5
630	6.7	6.0	5.8	5.3
710	9.4	8.4	7.8	7.0
800	13	11.5	11	10
900	17	15	14	13
1000	23	20	20	18
1120	31	27	26	24
1250	45	40	37	34
1400	66	59	55	50
1600	94	84	76	69

The first exchange of lubricating oil must be performed after about 3 months' operation, namely dismantle the coupling, thoroughly clean away the inside to remove the used oil and abrasion particles etc., reassemble it so that the same teeth before dismantling can be meshed each other again, and feed fresh oil from the plug hole; thereafter, supplement or exchange the oil every 6 months. Grease lubrication is inferior to the oil lubrication in its lubricating performance. When using grease, be sure to apply the recommended grease on the coupling gears (internal and external gears) to such an amount that their addendums can not be seen any more, and assemble them in. After fastening the coupling case, fill the case with a specified amount of grease from the oil plug hole by the use of a grease gun, etc. Intervals of exchanging grease are the same as those of the above-mentioned lubricating oil. When exchange grease, dismantle the coupling and exchange the entire used grease for the new one. In reassembling the coupling, be sure to keep the same gear teeth meshing as before dismantling. Refer to the following lists regarding lubricating oil brands and required lubricating oil amounts.

Maintenance and Check

⚠ WARNING

- Take appropriate measures to prevent rotating the drive and the driven gear securely when inspecting the condition of the surface of the gear teeth. Otherwise, you may be caught in the gearwheels, which may cause an accident resulting in injury or death.
- Do not operate without providing the safety cover which was removed during inspection. Otherwise an accident resulting in injury or death may be caused by being caught in the rotating part.

1. Check for vibrations and noises.
2. Check for oil leakage.
3. Check for damages on gear teeth.
4. Check for damages and deterioration on O-ring.
5. Check for lubricating oil deterioration.
6. Check for oil consumption.

The above items Land 2. can be checked by observation from the outside, so that always check them comparing with the conditions under normal operation. The other items than the above should be checked every 6 months by dismantling in principle. Under high ambient temperature, extreme over-load operation, frequent normal and reversing runnings, and large parallel misalignment and angular misalignment, be sure to shorten the checking interval.

Allowable Amounts of Misalignments

The following tables show the allowable amounts of misalignments determined by a structural consideration. It is, therefore, practically recommended that the alignment should be made as accurately as possible according to the service conditions such as the place of application, type of machine, service rpm, etc.

Recommended amount for centering : with 1/10 of following table

(a) Amount of angular Misalignment

Table 3

Types	Amount of (θ)
GC-SSM. GC-SMM	3°
GC-CCM	2°
GC-SMV	0.5°

Types	Amount of (θ)
GC-SEM	1.5°
GC-CEM	1°

(b) Amounts of offset Misalignment (δ) and axial float (α)

Table 4

Types GC-SSM. GC-SMM. GC-CCM

(m/m)

Unit size	(δ)	(α)
100	0.75	-0.5 ~ +1.0
112	1.0	-0.5 ~ +2.0
125	1.0	-0.5 ~ +2.5
140	1.25	-0.5 ~ +2.5
160	1.25	-0.5 ~ +3.0
180	1.5	-0.5 ~ +3.0
200	1.5	-0.5 ~ +3.0
224	1.5	-0.5 ~ +4.0
250	2.0	-0.5 ~ +4.0
280	2.0	-0.5 ~ +4.5
315	2.5	-0.5 ~ +5.5
355	3.0	-0.5 ~ +5.5
400	3.0	-0.5 ~ +5.5

Types GC-SMV

(m/m)

Unit size	(δ)	(α)
100	0.6	-0.5 ~ +1.0
112	0.6	-0.5 ~ +1.0
125	0.6	-0.5 ~ +1.5
140	0.6	-0.5 ~ +1.5
160	0.6	-0.5 ~ +1.5
180	0.6	-0.5 ~ +1.5
200	0.6	-0.5 ~ +1.5
224	0.6	-0.5 ~ +2.0
250	1.0	-0.5 ~ +2.0
280	1.0	-0.5 ~ +2.5
315	1.0	-0.5 ~ +3.0
355	1.0	-0.5 ~ +3.0
400	1.0	-0.5 ~ +3.5

NOTE : The types SEM & CEM can not absorb the offset misalignment (δ) by itself, whose axial float (α) will be half of the amount given above

For the types SEM&CEM, two sets of either type should be used with an intermediate shaft as shown in Fig.3.

In this case, the amount of offset misalignment can be obtained from the following equations.

$$\tan \phi = \frac{\delta}{L} \text{ or } \delta = L \times \tan \phi$$

usually taking as $L \doteq L'$

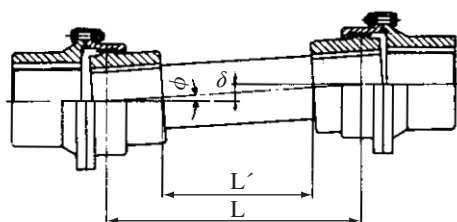

Fig. 3